



ELECTRICAL EQUIPMENT AUTOMATIC TEST SYSTEM MODEL 8900

Because the requirement in standard of the electric product increase day by day, the testing cost then increasing. In order to help the manufacturer reduce testing cost and products risk effectively, Chroma provide 8900 electrical equipment automatic test system (ATS) be the best solution by program the test of the complicated procedure like the medical equipment safety and function test and instrument safety and function test.

8900 electrical equipment ATS can completion that amount measurement and test procedure in once automatically. This strong function not only can be report formatted simply, but reduce the careless mistake of the artificial writing and improper test. Chroma 8900 electrical equipment ATS is suitable for all electrical equipment test solution within Electrical Safety Test.

Chroma 8900 electrical equipment ATS solve the Electrical Safety Test and special

FUNCTION test solution. The system can combine different testers in the system according with different test request what your need. The software is all open architecture structure which can offer the corresponding program and the most flexible test item in accordance with special test procedure to the customer for special products.

The all open architecture software of 8900 systems includes the strong report editor and generator, statistical analysis and functions of management. Management of various types of different test reports and operation that these functions make the system have the ability to control quality and reduce risk. These statistical analysis and report function are indispensable for quality control and product line testing in a modern electrical manufacturer.

MODEL 8900

Function :

- Support electrical safety test and function test scanning :
 - AC/DC WV Test
 - IR Test
 - GB Test
 - LC Test (all types)
 - Function test
- Expandable Measurement function
 - LCR Meter
 - AC/DC Source
 - DC Load
 - Power Analyzer
 - Timing/Noise Analyzer
 - DMM
 - Oscilloscope
 - Other hardware

Key Features :

- Open architecture software
- Expandable hardware
- Editable test library
- Editable test programs
- Editable and Test Item
- Editable reports
- Statistic report
- User authority control
- Activity log
- Support Barcode reader

Chroma



Medical Equipment

The safety standard of medical equipment is very strict. Because the medical equipment keeps in touch with the health of the doctor and patient frequently, make several EST test can't be ignore especially leakage current test which has already become the most important test in electrical safety test.

The leakage current test of medical equipment includes four kinds – ELC (earth leakage current), ECLC (enclosure leakage current), PLC (patient leakage current), PALC (patient auxiliary leakage current), - to test besides AC/DC/IR/GB test. Additionally, normal / reverse / single fault normal / single fault reverse four power switches and earth switch, let medical equipment safety test difficulty and complexity further.

Chroma 19200 can make up of different modules for special medical equipment test reached flexible and time saving. Chroma 8900 electrical equipment automatic test system with 19200 (8910 medical electrical safety ATS) can store Test procedure and result via computer for data mining and researching of line manager and Quality control department.

The following picture is that the basic circuit diagram of enclosure leakage current test in medical equipment safety test. There can be found in LINE/NETURAL Input and the second isolation transformer in the picture (join to SIP/SOP) and all need switch in four power switches (normal / reverse / single fault normal / single fault reverse). Adding function earth, protect earth, patient probe and two enclosure points ON/OFF are switched over severally. The matrix of test situation up to 128 sets just in one circuit diagram. There are over ten pieces of diagram in medical electrical safety requirement ,if you want to test at all, Chroma 8900/8910 electrical equipment automatic test system will be the best solution for all your need.

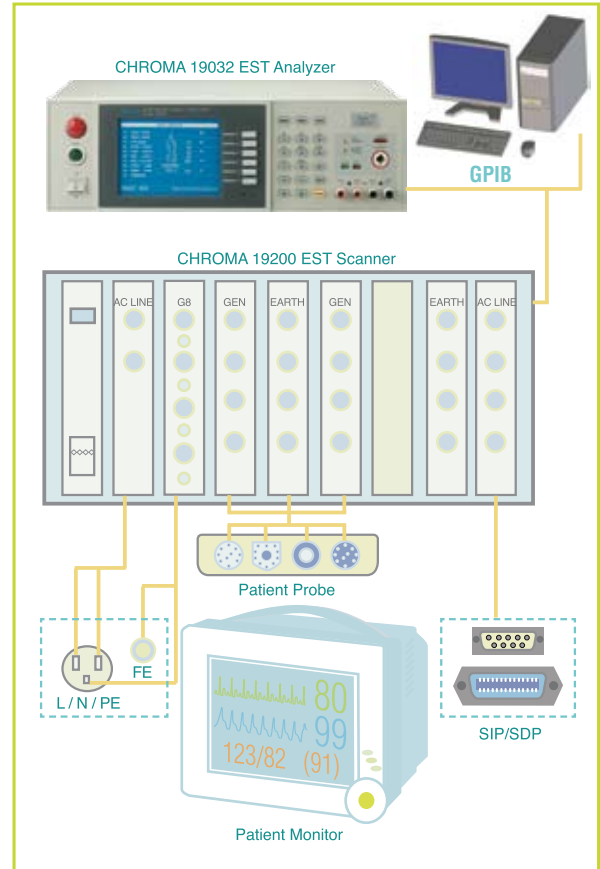

Automatic Test System for Patient Monitor

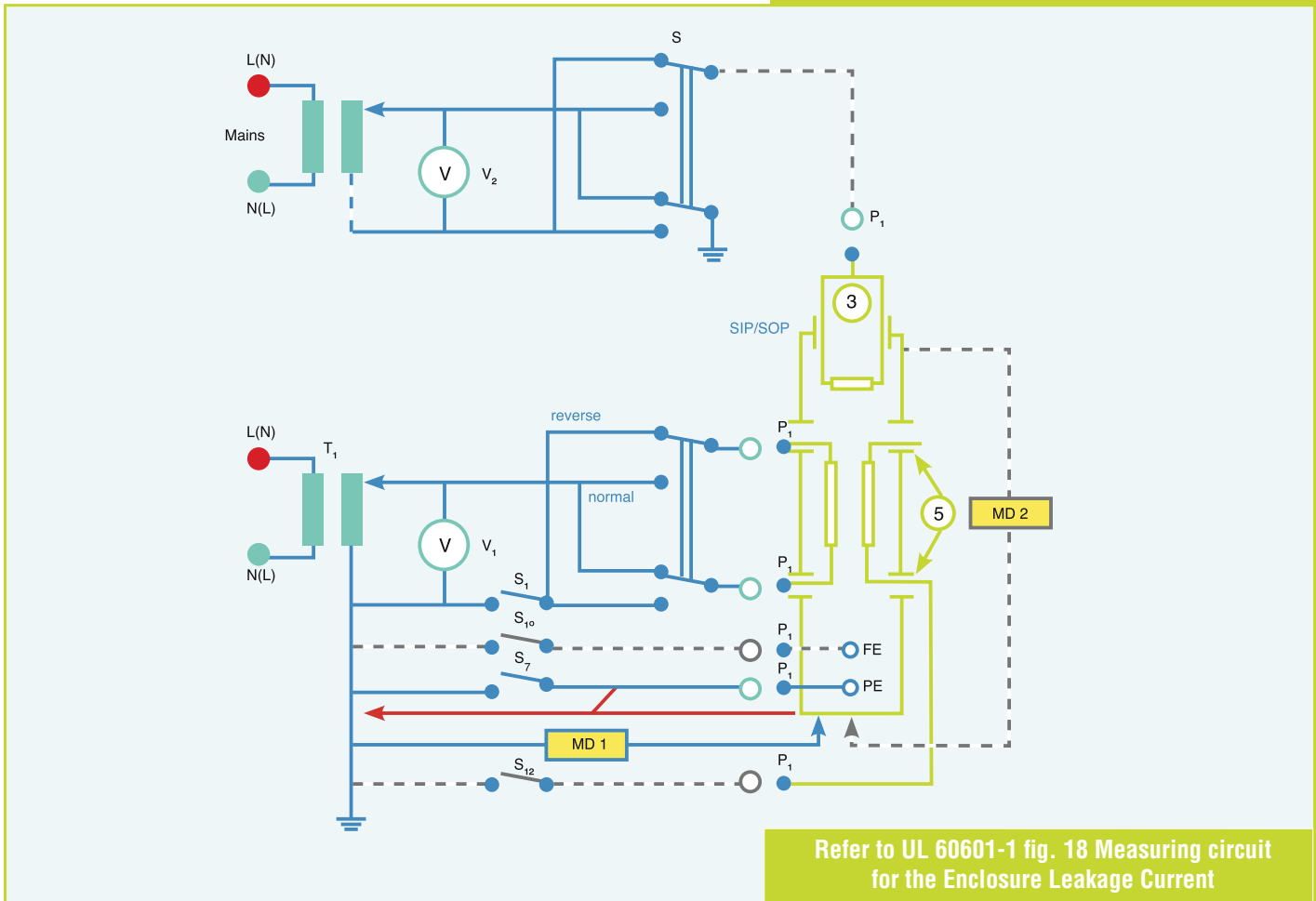

Refer to UL 60601-1 fig. 18 Measuring circuit for the Enclosure Leakage Current

UPS, Relocatable Power Taps (RPT) and multi-plug equipment

Because of UPS and relevant equipment of power, include single group power input and many group power output, transformer and cover, etc. all need safety test.

Chroma 8900 electrical equipment automatic test system with 19200 can make up of max. 8 modules include 16 points for GB test. 19200 support master/slave connection, you can test all electrical safety test (AC/DC/IR/GB/LC) of UPS With max. 9 slaves of 19200 to saving your time and cost.

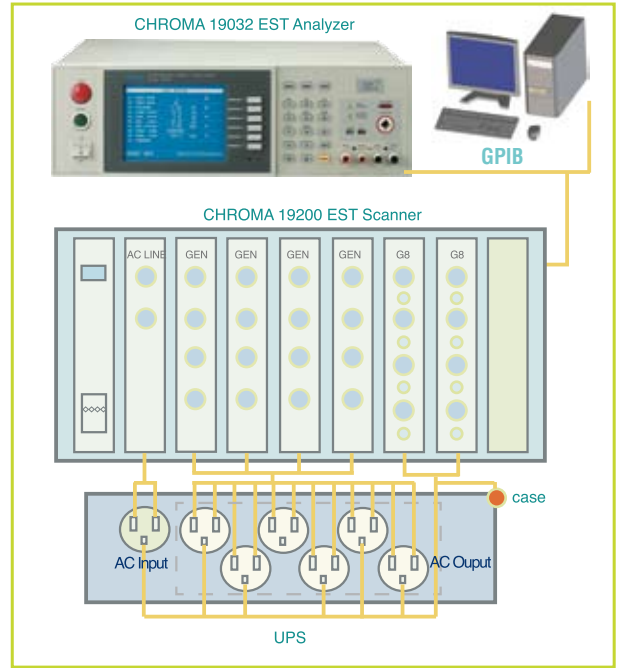

Function Test ---- Other Instruments combination

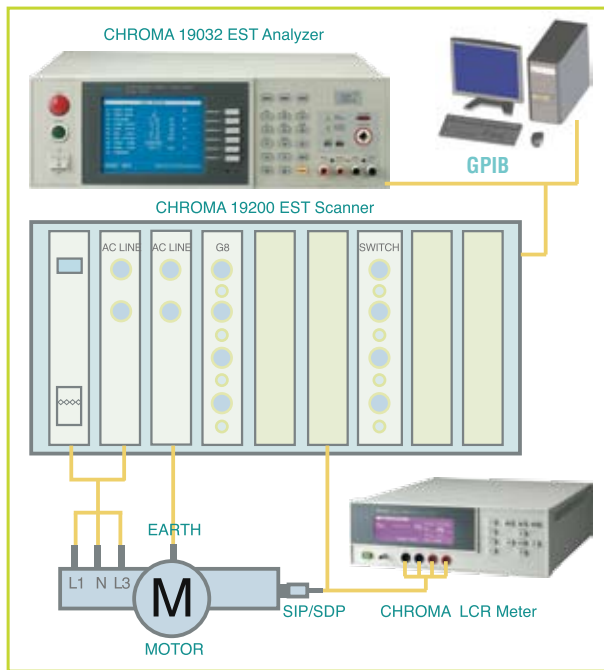

Chroma 8900 electrical equipment automatic test system with 19200 can support special product test by different module and different instrument combination like LCR meter, speed meter, bright meter.

For example, lifting motor need AC / DC / IR / GB / LC safety test, and CW/ CCW of motor test, variable resistance test, motor capacitor C measurement, switch/relay check etc. Medical equipment need signal test, ECG simulating test, etc.

Chroma 19200 with 8900/8910 test system can support all above test by test programming and saving data for QA analysis and data mining.



The Model 8900 Electrical Equipment Safety automatic test system include the industries most sophisticated power supply testing software platform, Chroma ATS software. The Chroma software provides users with an open software architecture suited for a wide range of applications. This software can offer engineer a simply environment with allowing to use resources that Microsoft window offered in Windows 98 / 2000 / NT/XP. Test system use a perfect test technology prevent the repeated control from being given to the system hardware device. The technology of Chroma 8900 electrical safety automatic test system promote testing the test speed and higher efficiency to be a perfect automatic test system.

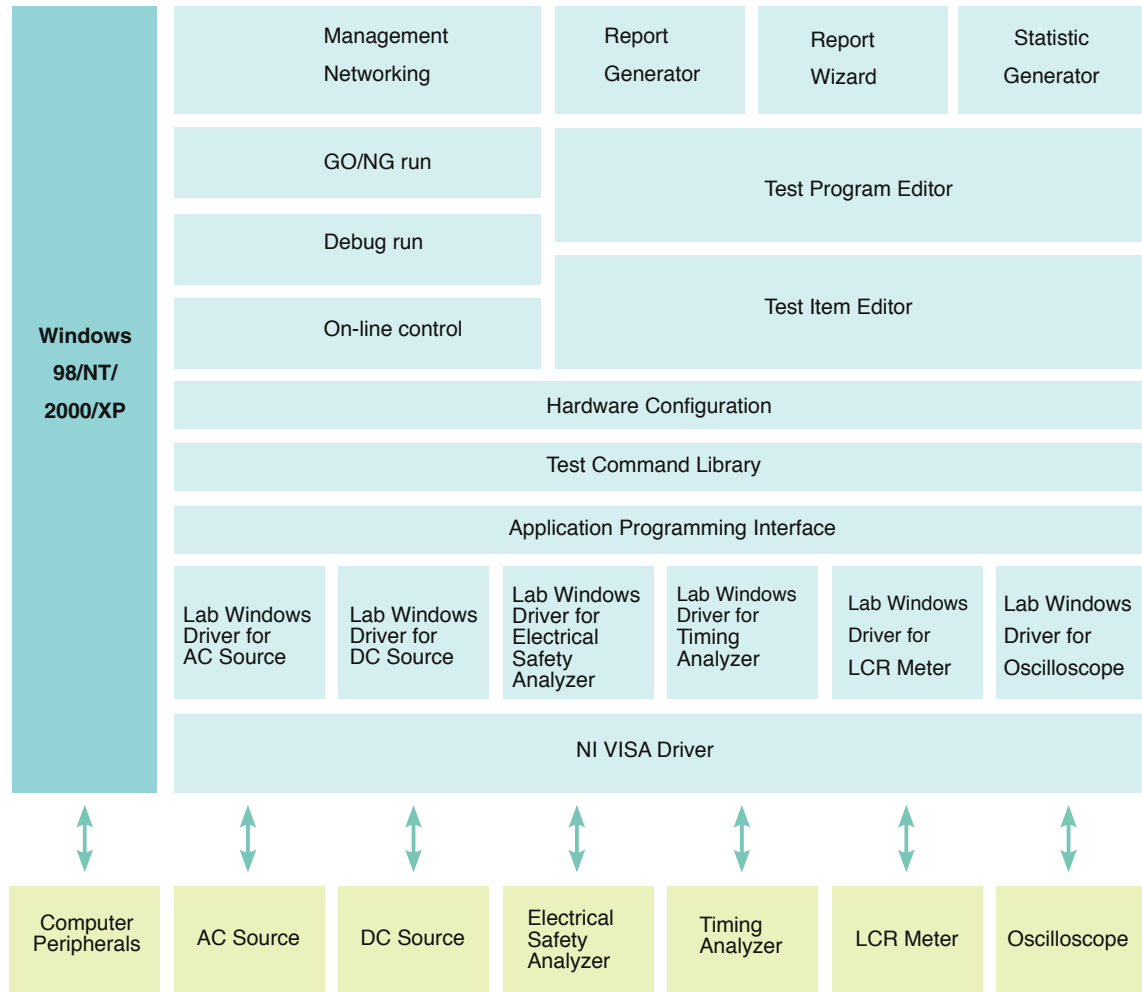

Maximum flexibility and expendability

NI VISA Driver

National Instrument VISA driver are used by software to allow support to almost any instrument which uses GPIB/RS-232/RS-485 interface protocols. As a result, users do not have you concerned about which interface is provided by individual instrument that may want to intergraded into system. By using these standard instrument drivers can incorporated almost any modern test device.

Higher compatibility

Application Programming Interface

When users want to change the equipment from one brand to the others, for traditional ATS design, users are prohibited to do that. The main problem is caused by the different format of the remote commands. Chroma software provides a unique application programming interface which interprets the different remote commands of various instrument to a standard format. Thus, if the functions of two equipment are identical, even manufactured by two different suppliers, they still can be replaced directly by adding a new application programming interface driver in Chroma ATS software.

Off-the-shelf test commands

Test command library

For some special controls, it is not very easy for most of the users to figure out how to make relevant instrument work properly. Chroma ATS software collects most useful test commands for users in order to provide user-friendly editing environment. On the other hand, Chroma ATS software also provides some low level test commands, such as GPIB read/write, RS-232 read/write, RS-485 read/write ... etc. That allow users to have the full access to all the equipment on 8900 electrical equipment safety automatic test system directly. Meanwhile, The test command library stops the repetitive test conditions from sending to hardware devices; Thus it can improve the test speed dramatically.

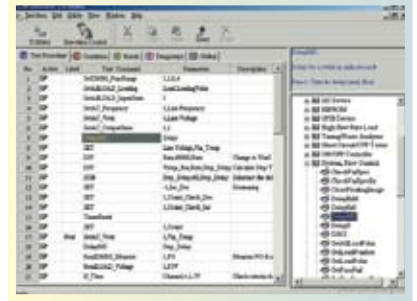

Add test command to the test procedure from test command library.

Flexible and easy to use

Test item editor

Following with the test command library, Chroma ATS software provides an editing environment for user to create new test items to fit new test requirements. In this test item editor, Chroma ATS software establishes a powerful tool which is similar to the C language, but much easier to learn and operate.

In the test item editor, it allows users to define test procedure, test condition variables, test result variables and temporary variables. Furthermore, Chroma ATS software test item editor also provides global variables for advanced control test requirement. For instance, it may be used for automatic alignment system which need to pass the aligned value of the previous UUT as the next UUT's default value. In this way, it is very helpful to improve the align speed .

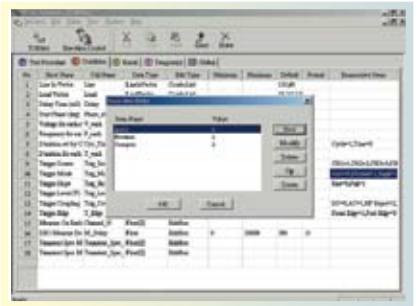

Enumerative items allow programmers define limited selections for low level users.

Sequential and Batch testing

The program editor

The test program editor provides a useful means to link several pre-defined test items for batch test. It also introduces pre-test and post-test functions which allow users to send the test commands that are not necessary to use all the time to the equipment on system but only when the execution just begin, or on the opposite, at the end of the test. This feature helps to optimize the test program and reduce test time. Meanwhile, its run-time control allows users to determine the process and the direction of the test program according to the individual test result of test items.

Test program editor can also open a M/S Excel file as the source of test program data. Users may first export test program as M/S Excel file. Then base on the external database. Users may create new test programs by modifying the Excel database. Thus, only one database needs to maintain for multiple test programs.

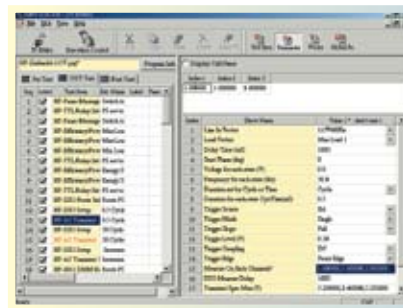
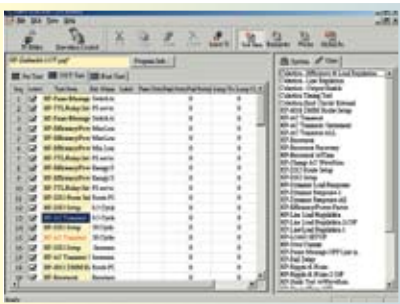

Test program can be created by stacking test items in test library.

Just fill the test conditions! The test procedure was defined in the test item library.

Versatile and powerful execution mode

Chroma ATS software platform provides three execution modes. DEDUG RUN is used to verify the user-defined test items and test programs. For production line testing, GO/ NG RUN allows one key operation to perform Pass/ Fail test. And the On-LINE-CONTROL mode extends Chroma Electrical Equipment Automatic Test System model 8900 to control and monitor the hardware devices simultaneously. Thus, it is capable of simulating the manual test scenarios just like you did on the bench.

Debug run

The debug run provides a versatile and immediate tool for users to verify the test items and test programs created before releasing them to operators. All the essential debugging tools are provided here, such as step run, set break point(s), run to break and simultaneous variables display. Users may use this to control the process of execution and at the mean time, monitor the test results and verify them. As a result, there's no risk for users to put an uncheck test item or test program onto production line.

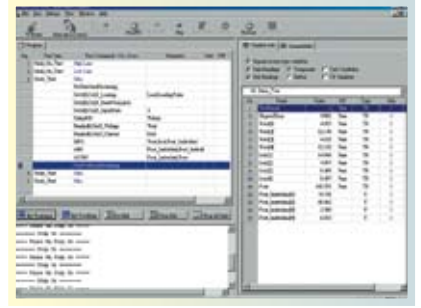

The selected variables will be updated simultaneously when the test item or test program is under going.

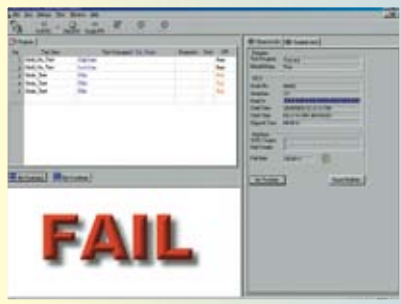

Failure rate check function is available in GO/NG execution mode.

GO/ NG run

The GO/ NG run provides friendly and easy execution environment for production line and operators. All the test programs tested here need to be released in management function. This may minimize the risk of running a wrong or unchecked test program. The test results will be stored in hard drive of the system controller which may be used to create statistic and the test report. Plus the fail rate check, bar code scanner support, Pass/ Fail indication TTL signal. All these powerful features make it an ideal tool for mass production testing.

On line control

The display tells it all. Users may achieve all the instrument on system to control them and get readings from them. The type of reading showing on display could be selected by user and user may even define specifications for them. Furthermore, user can also select them to show as a time graph in order to see the trends. And, the waveform measured by DSO can be merged onto the same display as well. The waveform can be downloaded as hard copy or digitizing waveform. Under digitizing mode. Users can select measurement parameters just like it provides in DSO. In a word, this execution mode is the implementation of virtual instrumentation.

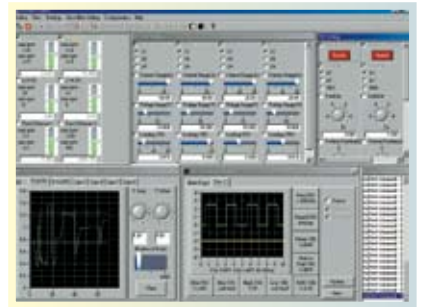

Users allow to create their own softpanel layout and store it for recall later.

Comprehensive analyzing tools

Report generator & wizard

Documentation and offering a readable report has been the weakest part of the traditional automatic test system. Users usually need to spend a lot of effort to modify the data stored by the automatic test system to make it more recognizable to their customer. During the process, it has great chance to get an incorrect result due to typing error.

Now, Chroma ATS software, its outstanding report wizard and generator provide the total solution for any documentation requirement. From tabular test data, DSO waveform to correlation chart, it allows users to integrate different types of presentation in the same report. Users may also edit and store report format for next use, thus it saves a lot of precious time in creating test report. Meanwhile, to make the test report more portable, the output of the report wizard is already a standard M/S Word file.



Define parameters and waveform preview Report Wizard.

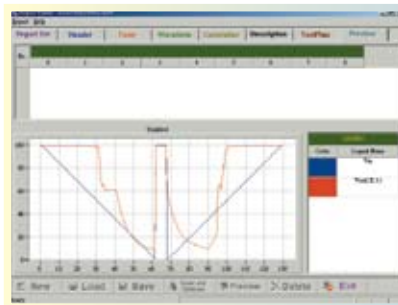

Preview the correlation chart in Report Wizard before converting it to M/S Word file.

Statistical report

Chroma ATS software provides off-the-shelf statistic report function. All the test conditions defined in the test program and the test readings can be stored and analyzed by statistic report function. In statistic report function, it provides process capability, Pareto, Xbar-R chart, Xbar-S chart, nP chart, P chart, U chart and C chart. Users may select test program, test date period and even include test data from remote computer via network connections. Then choose any one of the control chart to generate statistical report. The report may be printed out or stored in file. Or users may store the raw data as a text file directly which is able to be imported by Excel or similar word processor software package for further analysis.

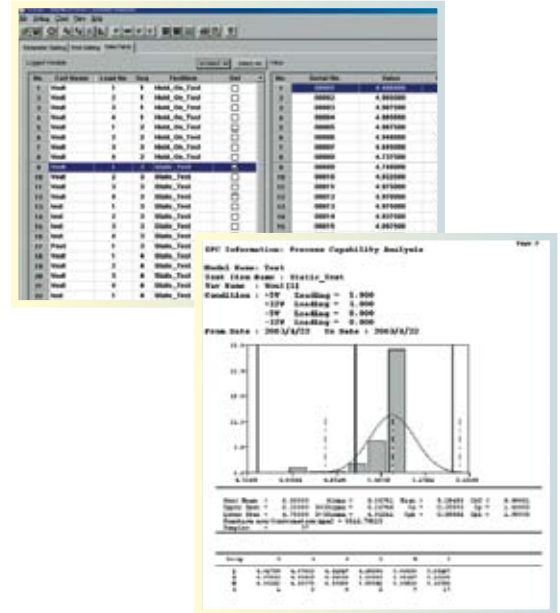

Example of statistic report - Process Capability

MANAGEMENT FUNCTION

Management

Chroma software provides a series of management functions for advance system control and management.

User Function

User function allows users to define authorized person list and their authorized level.

Activity log

Activity log records the historical log-in, log-out time and activated functions of the system users.

Release

Users are allowed to define the release flags of test programs and test items. These flags will be used to check if the test program can be executed by GO/ NG run. Or if the test item can be shown in user test item library.

Instrument

Instrument function is used to import and export H/ W instrument drivers.

Network

Network function provides interface for software to communicate with external software package or system. For example, Shop-Floor or Product-Data-Management system. It is also used to define the source location of the test programs when users want to centralize them.

Hardware configuration

The hardware configuration function allows users to define the system configuration by selecting devices from the instrument list defined in the "Instrument" section of Management function.

Shop-Floor control system

For modern mass production line, it is a big challenge to have the full control of the scenarios happened on production line. Therefore, Shop-Floor control system is widely used to improve fabrication process.

To satisfy customers' requirement, Chroma also provides customized Shop-Floor control system. For details, please contact your local representative of Chroma ATE INC.

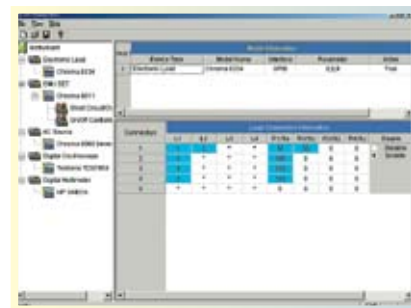

Parallel setting for E-loads allow users to control multiple load channels as one.

Example : 8900 Electrical Equipment Automatic Test System for motor

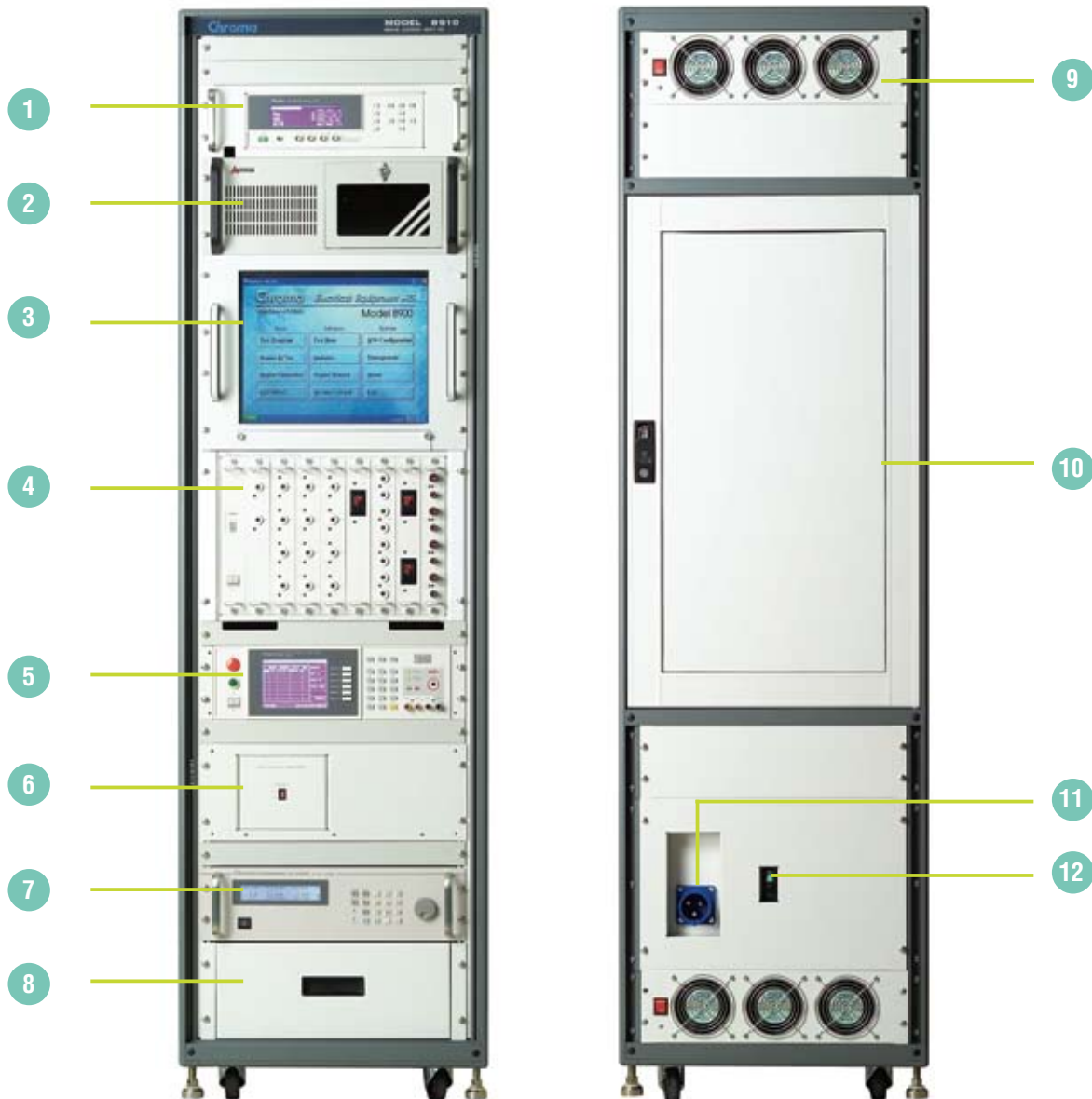

1. LCR meter: Model 11022/11025 Series LCR meter.
2. Industrial Personal Computer
3. Display: 15"/17" LCD monitor
4. Electrical Safety Test Scanner: Model 19200 Electrical Safety Test Scanner
5. Electrical Safety Analyzer: Model 19032 Electrical Safety Analyzer
6. Isolation Transformer: 500VA/1000VA Isolation Transformer #1 and #2 for LC Test of model 19032
7. AC Source: Model 6400/6500/61500/61600 series AC Source
8. 4U Drawer
9. Fans
10. Rear door
11. System power inlet: 1Ø 3W/ 30A
12. Power switch

* Other devices supported upon request

Electrical Safety Analyzer

Chroma electrical equipment automatic test system model 8900 supports Chroma Model 19032 for all Electrical Safety Test included Withstand Voltage Test AC/DC, Insulation Resistance Test, Ground Bond Test and Leakage Current Test. This is a total solution for R&D, QA and product line department to verified all kinds of equipment and appliance.



Model	19032	
Function	Output	Range
Withstanding Voltage Test	AC 5kC/ DC 6kV	Cutoff current: AC 40mA/DC 12mA
Insulation Resistance Test	DC 1kV	IR: 1MΩ~50GΩ
Ground Bond Test	30A (40A option)	GR: 10mΩ ~ 510mΩ
Leakage Current Test	300V/10A,300V/20A	Current: 0.1~590uA / 500~6000uA
(*Option -Line to Earth, Probe to Earth and Probe to Probe)		

Electrical Safety Scanner

Chroma electrical equipment automatic test system model 8900 can support all Chroma Model 19200 Electrical Safety Test Scanner. Model 19200 supports 5kVac/6kVdc high voltage output, 40mA cutoff current and 20A current while Leakage Current Test. All test can be programmable and Integrated by GPIB, RS232 and USB interface.

Model 19200 shall be combine with Chroma 19032 in 8900 series for Electrical Safety Test.



Model	19200
Withstanding Voltage Test Scan Max. Voltage	AC : 5kV, DC : 6kV
Insulation Resistance Test Scan Max. Voltage	DC : 5kV
Ground Bond Test Scan Max. Current	40A
Leakage Current Test Scan Max. Voltage	AC 300V
Leakage Current Test Scan Max. Current	20A
Operation Environment	Temperature: 0°C ~ 45°C, Humidity: 15% to 95% R.H.@ ≤ 40°C

LCR Meter

The Chroma 11022 LCR Meters are the measurement instruments for passive components. They are applicable to the automatic manufacturers for passive components in material inspection. With the features of 21ms high-speed measurement and 0.1% accuracy, 11022 LCR Meter fulfills the requirements for fast production. Its functions of 8-level counting, pass/fail judgment, and 50 sets of internal save and recall settings totally meet the production line requirements for easy operation.



Model	11022
Test Parameter	L, C, R, Z , Q, D, ESR, X, θ
Test Signals	
Level	10 mV~1V , step 10 mV; (10% + 3 mV)
Frequency	50Hz, 60Hz, 100Hz, 120Hz, 1kHz, 10kHz, 20kHz, 40kHz, 50kHz, 100kHz ; $\pm 0.01\%$
Measurement Display Range	
C (Capacitance)	0.001pF ~ 1.9999F
L, M, L2 (Inductance)	0.001 μ H ~ 99.99kH
Z (Impedance), ESR	0.01mΩ ~ 99.99MΩ
Q (Quality Factor)	0.0001 ~ 9999
D (Distortion Factor)	
θ (Phase Angle)	-180.00° ~ +180.00°
Basic Measurement Accuracy (Note1)	$\pm 0.1\%$
Measurement Time (Fast) (Note2)	21ms

Note 1 : $23 \pm 5^\circ\text{C}$ after OPEN and SHORT correction.Slow measurement speed.Refer to Operation Manual for detail measurement accuracy descriptions

Note 2 : Measurement time includes sampling,calculation and judge of primary and secondary test parameter measurement.

AC Power Source

Chroma electrical equipment automatic test system model 8900 supports all Chroma Model 6400, 6500, 61500,61600 and 61700 series AC power supplies. They provide stable and clean AAC or DC (Model 61500/61600 series) output and power line disturbance simulation for advanced power supply input characteristic testing)



Model	6400series	6500series	61500series	61600series	61700series
Power rating	375-9000VA	1200-9000VA	500-4000VA	500-4000VA	1500-12000VA
Voltage range	0-300V	0-300V	0-300V	0-300V	0-300V
Output phase	1 or 3 phases	1 or 3 phase	3 phases	1phases	3 phases
DC output	No	No	Yes	Yes	Yes
Output measurement	Yes	Yes	Yes	Yes	Yes
Harmonic measurement	No	No	Yes	No	No
Waveform simulation	No	Yes	Yes	No	Yes
Programmable impedance	No	No	Yes	No	No
Harmonic synthesis	No	Yes	Yes	No	Yes
Inter-harmonic synthesis	No	No	Yes	No	Yes

DC Power Source

Chroma electrical equipment automatic test system model 8900 supports all Chroma Model 6200, 6200K ,6200F, 6260, 62120, 62000P series DC power sources which may be used as line-in or OVP sources.



Model	6200 series	6200K series	6200F series
Power rating	60-1000W	1000-3000W	1200-12000W
Voltage range	0-5V/ 150V	0-5V/ 600V	0-5V/ 600V
Programmable current limit	Yes	Yes	Yes
Programmable OV point	Yes	Yes	Yes
Analog programming	Yes	Yes	Yes
Remote sensing	Yes	Yes	Yes
Line-drop compensation	5V	1V	5V

Model	6260 series	62120 series	62000P series
Power rating	6000W	12000	600-1200W
Voltage range	0-10V/ 600V	0-10V/ 600V	0-100V/ 600V
Programmable current limit	Yes	Yes	Yes
Programmable OV point	Yes	Yes	Yes
Analog programming	Yes	Yes	Yes
Remote sensing	Yes	Yes	Yes
Line-drop compensation	5V	5V	5V

Power Analyzer / Meter

Chroma electrical equipment automatic test system model 8900 also supports all Chroma model 6630,6632 series power analyzer,and model 66200 series power meter. They do not only provide traditional high precision power measurement, but also the voltage/current harmonics measurements defined in IEC and EN regulation.



Model	6630	6632	66201	66202
NO. of input module	1 to 3	1 to 3	1	1
Power measurement range	48 ranges	48 ranges	12 ranges	24 ranges
Voltage measurement range	6 ranges	6 ranges	3 ranges	3 ranges
Current measurement range	8 ranges	8 ranges	4 ranges	8 ranges
Front panel display	Yes	No	Yes	Yes
Front panel editable	Yes	No	Yes	Yes
Harmonics measurement	Yes	Yes	No	Yes
Flicker measurement	Yes	No	No	No
Waveform measurement	Yes	Yes	No	Yes
Build-in regulation limit	Yes	Yes	No	No

DC Electronic Load

Chroma electrical equipment automatic test system model 8900 can support all Chroma Model 6300, 6310, 6330, 63200 and 6340 series DC electronic load. They come with different powers, load modes, slew rates and features. This provides users maximum selection opportunities for different test application requirements.



Model	6300 series	6310 series	6330 series	63200 series	6340 series	63472
Load mode	CC/ CR/ CV/ CP	CC/ CR/ CV	CC/ CR/ CV	CC/ CR/ CV/ CP	CC	CC
Power rating	60-300W	30-1200W	30-1200W	2000-12000W	625W	200W
Voltage range	1-254V	1-500V	1-500V	1-500V	0.8-50V	0.5-2V
Current range	Up to 60A	Up to 240A	Up to 240A	Up to 600A	Up to 150A	150A
Slew rate	Up to 2.5A / μ s	Up to 10A / μ s	Up to 10A / μ s	Up to 25A / μ s	Up to 150A / μ s	1000A / μ s
Measurements	Voltage/Current /Power	Voltage/Current	Voltage/Current	Voltage/Current /Power	Voltage/Current	Voltage/Current
Monitoring output	Current	No	No	Current	Voltage/Current /Power	Voltage/ Current
Current share measurement	No	No	No	No	Yes	No
Noise measurement	Optional	No	No	No	No	No
Voltage sense input	Yes	Yes	Yes	Yes	Yes	Yes
Sync Signal	No	No	Yes	Yes	No	No
High Speed	No	No	Yes	No	No	No

Timing / Noise Analyzer

Chroma electrical equipment automatic test system model 8900 provides an unique timing / noise analyzer, Chroma Model 6011. Its modular design allows users to expand up to 10 input measurement modules. Each module is capable of measuring timing period and noise level. Furthermore, it also provides 16 bits TTL signals and 6 pairs of floating relays for external control. Meanwhile, the 10 multiplexer inputs and 2 DMM and 2 DSO outputs further extend the Chroma Model 6011 for advanced measurement requirements.

Model	6011	80611
NO. of input module	Up to 10	Up to 10
Noise measurement range	2V/ 0.4V	2V/ 0.4V
Low Pass Filter	Up to 20MHz	Up to 20MHz
Input circuit	Differential input	Differential input
Timing range	0-16/ 0-64 second	0-64 second
NO. of trigger input	4 sets	6 sets
NO. of comparator	2 / Input modules	4 / Input modules
Controllable TTL bits	16 output	16 Output/ 16 Input
Controllable floating relay	6	8
NO. of multiplex input	10	10
NO. of multiplex output	2 for DMM & 2 for DSO	1 for DMM



Digital Multi-Meter & Storage Oscilloscope

Chroma electrical equipment automatic test system model 8900 support Agilent 34401A / 34970A and Keithley 2700 series DMM and most of Tektronix scopes . Other DMM and DSO are supported upon request.

ORDERING INFORMATION

System		
8900	Electrical Equipment ATS	
8910	Medical Electrical Safety ATS base on 8900	
Instrument		
Electrical Safety Analyzer	Refer to Model 19032	
Leakage Current Test Module	6000-05(10A) and 6000-07(20A) for 19032	
Multi Channel Module	6000-01 (3GC/5HV), 6000-02 (5GC/3HV), 6000-03 (8HV), for 19032	
Isolation Transformer	500VA (A190313)/ 1000VA(A190314)	
Electrical Safety Test Scanner	Refer to Model 19200	
Scan Modules for 19200	AC Line Module(A19200000)	General Module (A19200002)
	AC Line2 Module(A19200003)	Earth Module (A19200004)
	GB Module(A19200005)	GBF-1 Module (A19200006)
	GBF-2Module(A19200007)	Switch Module (A19200008)
LCR Meter	Refer to Model 11022, 11025	
AC Source	Refer to Model 6400, 6500, 61500, 61600, 61700 Series	
DC Source	Refer to Model 6200,6200K,6200F,6260,62120,62000P Series	
Power Analyzer	Refer to Model 6630, 6632 Series	
Power Meter	Refer to Model 66200 Series	
DC LOAD	Refer to Model 6300, 6310, 63200, 6330, 6340, 63472 Series	
Timing/Noise Analyzer	6011/80611	
Timing/Noise module	6011N/80611N	
Cable and Accessory		
A600009	GPIB Cable (200 cm)	
A600010	GPIB Cable (60cm)	
A800005	PCI Bus GPIB Card (National Instrument)	

Developed and Manufactured by :

Distributed by:

CHROMA ATE INC.

致茂電子股份有限公司

HEADQUARTERS

66, Hwa-Ya 1st Rd., Hwa-Ya
Technology Park, Kuei-Shan Hsiang,
Taoyuan Hsien 33383, Taiwan
Tel: +886-3-327-9999
Fax: +886-3-327-8898
http://www.chromaate.com
E-mail: chroma@chroma.com.tw

U.S.A.

CHROMA ATE INC. (U.S.A.)
7 Chrysler Irvine, CA 92618
Tel: +1-949-421-0355
Fax: +1-949-421-0353
Toll Free: +1-800-478-2026

EUROPE

CHROMA ATE EUROPE B.V.
Max Planckstraat 4, 6716 BE
Ede, The Netherlands
Tel: +31-318-648282
Fax: +31-318-648288

CHINA

**CHROMA ELECTRONICS
(SHENZHEN) CO., LTD.**
8F, No.4, Nanyou Tian An
Industrial Estate, Shenzhen,
China PC: 518054
Tel: +86-755-2664-4598
Fax: +86-755-2641-9620

Worldwide Distribution and Service Network
8900-200612-PDF